

# Breadboard Radio 40 Meter Woodpecker Trans-Receiver

## INTRODUCTION

The 40 Meter Woodpecker is a dual frequency crystal controlled transmitter and VXO crystal controlled receiver for the 40 meter ham band. The transmitter produces approximately 500 milliwatts of continuous wave (CW) R.F. output. The transmitter provides sidetone, QSK, and muting for the receiver. The T/R delay is set to about one second which is fine for most slow to moderate keying. It may be set faster or slower by changing one component. The receiver has an attenuator, selectable lowpass / highpass audio filtering and an approximately 1.0 kilohertz tuning range. Audio output is suitable for earbuds / headphones.

## What You Can Expect

In testing, the prototype was used with a 13.8 volt power supply and a 40 meter dipole antenna fed at 60 feet above ground with a 1:1 balun and 150 foot run of RG-8 type coax. During this test period W4FSV worked over 20 stations...not bad for this simple little rig. If I can do it, you can too! It only takes patience, persistence and a decent antenna...not luck. With a half watt you won't get an answer after every CQ or every CQ you answer, but those contacts you do make will truly be rewarding.

## PLEASE:

1. Take your time. We recommend that you take at least three or four days to complete your kit. So, if you take your time, in four days you can have a beautiful working project that you will be proud to own and operate.
2. If you don't know how to solder parts on a circuit board, get help. Learning to solder is not hard, but please do not start this kit if you have never soldered before!
3. Most of the parts are tiny. Please use a magnifying glass.
4. Build the kit by the instructions, one parts bag at a time and check your work as each bag is finished.
5. Use protective eyewear.
6. Be careful with the ICs and transistors to avoid damage from static.
7. All parts should be mounted flush or as close as possible to the circuit board keeping leads short. After soldering, clip all wires close to the board.

## PARTS LIST

- 1 Circuit Board
- 1 2N2906 transistor
- 1 2N3904 transistor
- 1 2N3053 transistor
- 1 2N7000 transistor
- 1 NE555 I.C.
- 2 1N4148 diode
- 1 47 uf electrolytic capacitor
- 1 trimmer capacitor
- 11 0.1 uf disc capacitor
- 1 100pf disc capacitor npo
- 6 1k ohm 1/8 watt resistor
- 4 10k ohm 1/8 watt resistor
- 1 36k ohm 1/8 watt resistor
- 1 100 ohm 1/8 watt resistor
- 1 10k ohm 1/4 watt resistor

1 47pf npo disc capacitor  
1 470 ohm 1/8 watt resistor  
1 20 ohm 1/4 watt resistor  
1 22 uh choke red/red/black/gold  
1 15 uh choke brown/blue/black/gold  
2 1.0 uh choke brown/black/gold/gold  
1 RCA jack  
1 TO-5 heat sink  
2 1N4001 diode  
1 1N4002 diode  
2 7030 khz crystal  
2 7056 khz crystal  
1 LM06 voltage regulator I.C.  
1 TL431 comparator I.C.  
1 SA612AN mixer / oscillator I.C.  
1 100k ohm 1/8 watt resistor  
1 680 ohm 1/8 watt resistor  
1 1meg ohm 1/8 watt resistor  
1 470k ohm 1/8 watt resistor  
2 390pf disc capacitor npo  
1 82pf (820) disc capacitor npo  
2 150pf 560 disc capacitor npo  
1 47uf electrolytic capacitor  
1 4.7uf electrolytic capacitor  
1 56pf disc capacitor  
1 3900pf 392 disc capacitor  
1 10.7 mhz I.F. transformer  
1 2 position screw terminal  
1 1k ohm linear potentiometer  
1 10k ohm linear potentiometer  
1 10k ohm audio potentiometer with switch (SW1)  
1 SPDT slide switch (SW2)  
2 phone jack  
12 inches each red, white and black 24 ga, solid hook-up wire  
1 red LED  
1 3mm LED mounting bezel  
2 small knobs  
1 large knob  
4 #2 SS machine screws  
2 7/8 inch wood screw  
1 front panel decal  
2 rear feet  
2 front feet  
4 black spacers  
1 pre-cut front panel  
1 pre-cut base  
2 triangular supports  
2 8 pin dip ic sockets  
1 0.47 uf disc capacitor  
2 820pf (821) disc capacitor npo  
2 1200pf npo disc capacitor  
1 red 18ga wire

## Building the Circuit Board

Tools and supplies needed to build the circuit board:

1. needle nose pliers
2. diagonal cutters
3. small flat blade and phillips screwdrivers
4. Magnifying glass
5. 20-40 watt soldering iron
6. 60/40 thin resin core solder
7. Electrical tape

The board is assembled from four bags of parts. One additional bag (bag 5) contains the cabinet and front panel mounted parts.

Use the Circuit Board Parts Placement Page and enlarged circuit board diagram to mount the parts from bag #1, then parts from each bag #2 through #4. Solder each part and trim the soldered leads close to the board. Check your work after each bag for proper parts placement, shorts, solder bridges and good solder technique.

### NOTES PER BAG:

Bag #1. All resistors are 1/8th watt except R16 which is a 1/4 watt 1% and R10 which is 10K 1/4 watt. There are several 1K and 10K resistors...do not confuse the red and orange stripes.

Bag #2. The disc capacitors are very small. You should use a magnifying glass to confirm the value of each capacitor before installing it. Values are printed on one side in the standard 3 number code. C28 is a trimmer capacitor. The long lead on the electrolytic capacitors is positive.

Bag #3. All diodes, transistors and integrated circuits are in the static resistant red bag. Use 8 pin IC sockets for U1 and U4. Do Not Place the Heatsink on Q4 until all Bag #4 parts are mounted.

Bag #4. This bag contains the chokes, transformer and all other parts to complete the circuit board except for the control switches and potentiometers, which will be installed later. Install the phone jacks and LED last, following the detail instructions below. Place the heatsink on Q4 by spreading the gap with needle nose pliers or a screwdriver. Apply silicone heatsink grease if you have some.

## 40 Meter Woodpecker Circuit Board Parts Placement

### Resistors (Bag #1)

R1. 1K brown/black/red  
 R2. 10K brown/black/orange  
 R3. 1K brown/black/red  
 R4. 470K yellow/violet/yellow  
 R5. 1K brown/black/red  
 R6. 1M brown/black/green  
 R7. 680 blue/gray/brown  
 R8. 10K brown/black/orange  
 R9. 10K brown/black/orange  
 R10. 10K brown/black/orange 1/4w  
 R11. 36K orange/blue/orange  
 R12. 100 brown/black/brown  
 R13. 100K brown/black/yellow  
 R14. 10K brown/black/orange  
 R15. 1K brown/black/red  
 R16. 20 red/black/black 1/4w  
 R17. 1K brown/black/red  
 R18. 470 yellow/violet/brown

### Capacitors (Bag #2)

C1. 0.1uf 104  
 C2. 0.1uf 104  
 C3. 0.47uf 474  
 C4. 0.1uf 104  
 C5. 47uf electrolytic  
 C6. 0.1uf 104  
 C7. Not used  
 C7A. 150pf 151  
 C8. 4.7uf electrolytic  
 C9. 3900pf 392  
 C10. 390pf 391  
 C11. 47pf 470  
 C12. 0.1uf 104  
 C13. 56pf 560  
 C14. 270pf 271  
 C15. 820pf 821  
 C16. 820pf 821  
 C17. 390pf 391  
 C18. 0.1uf 104  
 C19. 100pf 101  
 C20. 0.1uf 104

C21. 0.1uf 104  
 C22. 47uf electrolytic  
 C23. 0.1uf 104  
 C24. 0.1uf 104  
 C25. 82pf 820  
 C26. 150pf 151  
 C27. 0.1uf 104  
 C28. 70pf trimmer

### Semiconductors (Bag #3)

D1. 1N4001  
 D2. 1N4001  
 D3. 1N4148  
 D4. 1N4148  
 D5. 1N4002  
 U1. NE555  
 U2. TL431  
 U3. L78L06  
 U4. SA612AN  
 Q1. 2N7000  
 Q2. 2N3906

Q3. 2N3904  
 Q4. 2N3053  
 Q4 Heatsink

### Inductors (Bag #4)

L1. Jumper wire  
 L2. 1.0uh brown/black/gold  
 L3. 1.0uh brown/black/gold  
 L4. 22uh red/red/black/silver  
 L5. 15uh red/blue/black/gold  
 T1. 10.7mhz transformer

### Other (Bag #4)

Y1. 7030 khz crystal  
 Y2. 7030 khz crystal  
 Y3. 7056 khz crystal  
 Y4. 7056 khz crystal  
 J1. 2pos screw terminal  
 J2. RCA jack  
 J3. 1/8 in. Phone jack  
 J4. 1/8 in. Phone jack  
 LED1. 3.0 mm LED

Note: All disc capacitors in pf range are npo

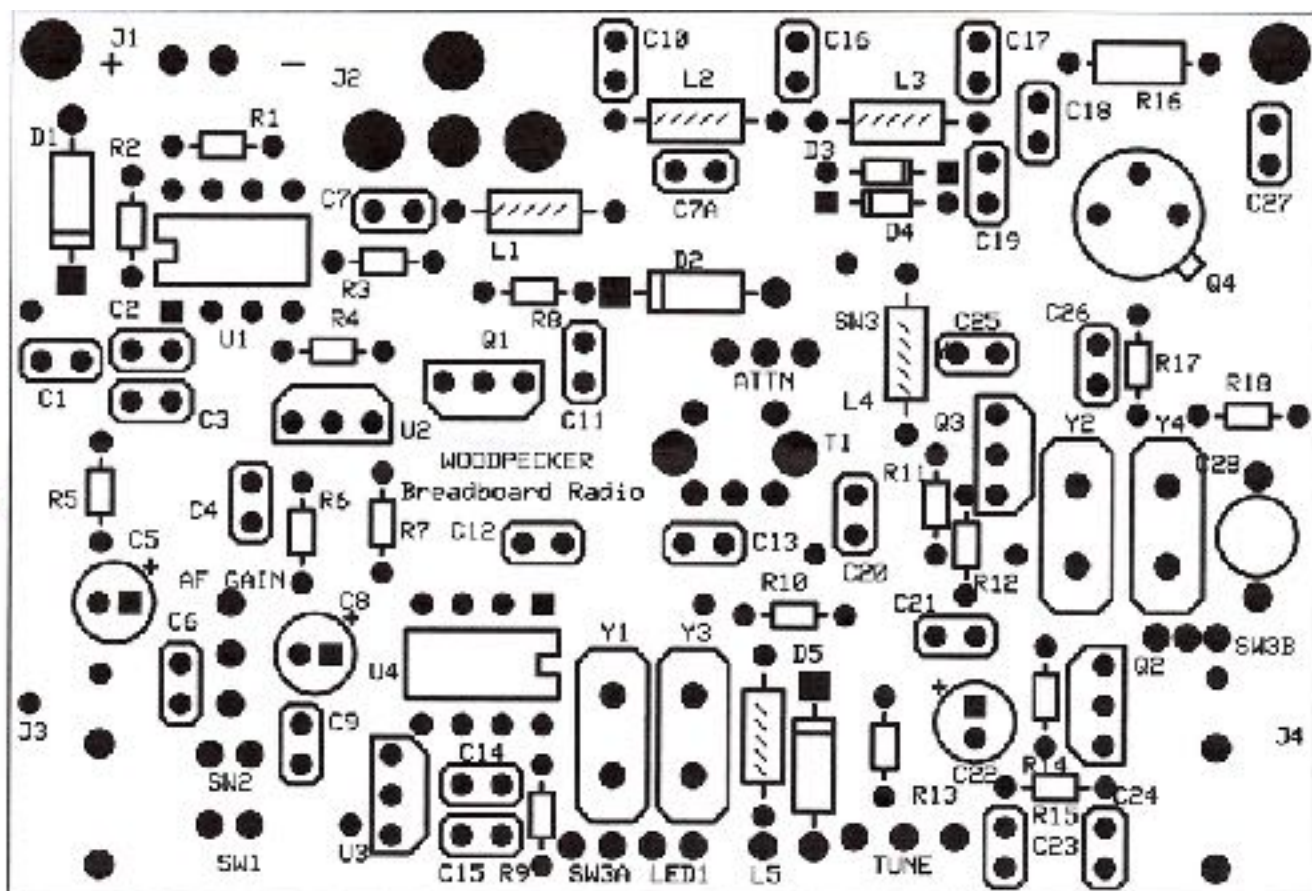

## PHONE JACKS (2) DETAIL

The two phone jacks are for the key and earphones/headphones. They must be slightly modified and mounted on the bottom side of the circuit board (soldered on the top of the circuit board).

Locate J3 a 1/8th inch phone jack and its mounting position on the left front side of the circuit board. Refer to diagram 1 and modify the two lower soldering lugs to fit in the two mounting holes closest to the left front side of the board. Bend the lower back lug (lug B) 90 degrees so that it points down like the front lug. Using diagonal cutters, clip off the ends of lugs A and B as close as possible to the soldering hole. The remaining lugs should be as long as possible so that they will fit through the mounting holes in the circuit board. Place J3 into position with lug A and B in the mounting holes and solder with J3 flush against the board (bottom side). The lugs may need slight trimming with the diagonal cutters to fit the holes. Lug B may not come all the way through the hole, but a little extra solder to fill the hole will sufficiently hold it in place. Use one of the wire leads saved from a resistor to complete mounting J3. Pass one end of the wire through lug C of J3 and into the circuit board mounting hole. Secure the top end of the wire to lug C of J3 and solder in place. Solder the other end of the wire on the top of the board and clip the excess wire.

Now repeat these steps to mount J4 to the right front of the circuit board.

Diagram 1.

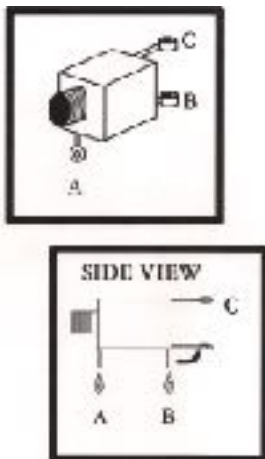

## L.E.D. DETAIL

The L.E.D. is mounted on the bottom of the circuit board. The leads will be soldered on the top of the circuit board.

1. Strip two 1/2 inch long sections of insulation from the supplied short 18 gauge red wire.
2. Place each section of insulation over each lead of the L.E.D. Note that the L.E.D. positive lead is longer.
3. Pass the leads through the mounting holes from the bottom of the circuit board. Note that the long lead (+) goes through the mounting hole on the right as you face the board.
4. With the leads through the holes until the insulation touches the bottom of the circuit board, solder the leads from the top of the circuit board. Do not prolong the soldering process as too much heat may melt the insulation on the wire leads.
5. Cut the soldered leads from the top of the circuit board.

## PREPARATION OF THE FRONT PANEL SWITCHES AND POTENTIOMETERS

### Bag #5

Use the photos below to attach wires to the switches and potentiometers. Note that potentiometers may have straight or round soldering tabs. In either arrangement, make a good mechanical connection before soldering! Notice the markings (A10K) and (B10K) on the potentiometers. A10K is the A.F. Gain pot and B10K is the Tuning pot. Once the switches and pots have been prepared, they will be soldered to the circuit board.



### SW2 high-low pass audio switch (SPDT)



Prepare SW2 with 2 inch black and white wires. Strip 3/8 inch of insulation from each end. Make good mechanical connections before soldering. Then twist the wires together. Solder the other ends of the wires to the two holes labeled SW2. Note that the wires go through the Bottom of the circuit board and are soldered from the top. The wires may go in either of the two holes.

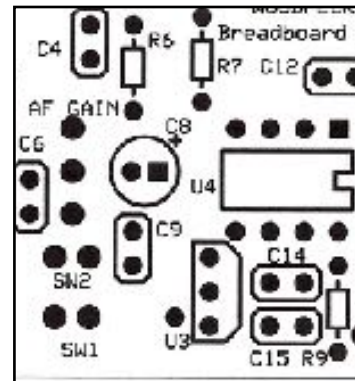
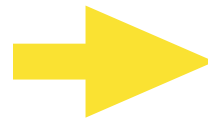

## A.F. Gain potentiometer (10K audio taper) and SW1 power on/off switch

Prepare A.F. Gain pot with three 2 inch (red, white and black) wires as shown. Strip 3/8 inch of insulation from each end. Make good mechanical connections before soldering. Then twist the wires together. Also strip a red and black 2 inch wire for SW1 (on the sides of the A.F. Gain pot).

Circles indicate wire color

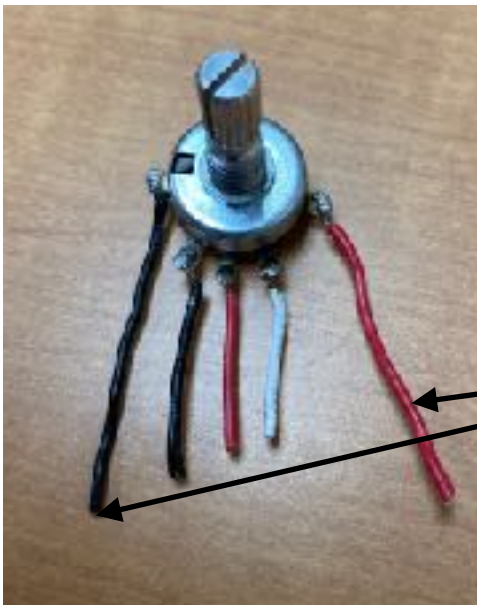
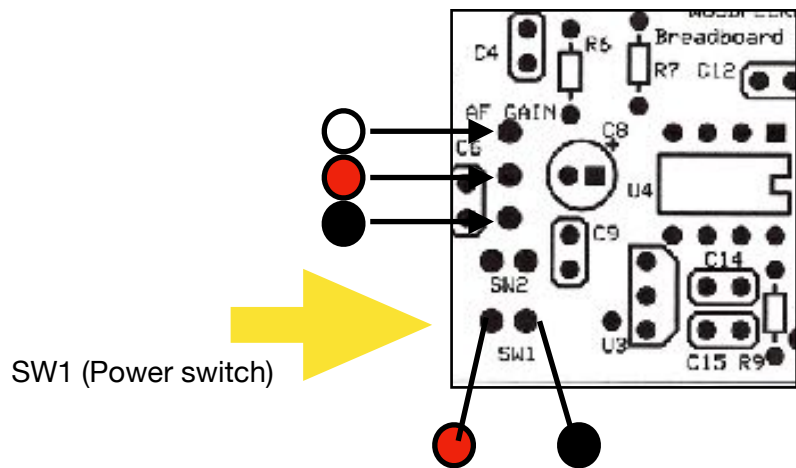

To SW1 on circuit board



### R.F. Attenuation Potentiometer (1K linear taper)



Prepare R.F. Attenuation pot with three 2.5 inch (red, white and black) wires as shown. Strip 3/8 inch of insulation from each end. Make good mechanical connections before soldering. Then twist the wires together as shown.

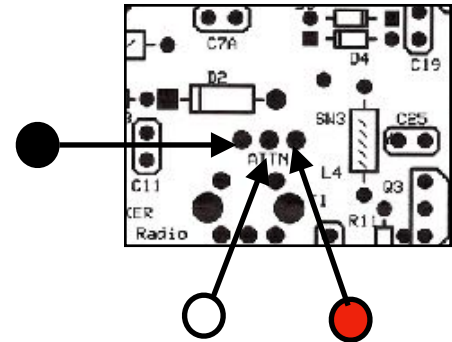

### Tuning Potentiometer (10K linear taper)



Prepare the Tuning pot with three 2 inch (red, white and black) wires as shown. Strip 3/8 inch of insulation from each end. Make good mechanical connections before soldering. Then twist the wires together as shown.

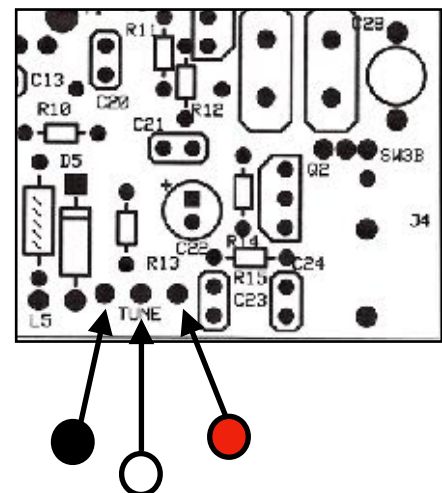

## SW3 Crystal Switch

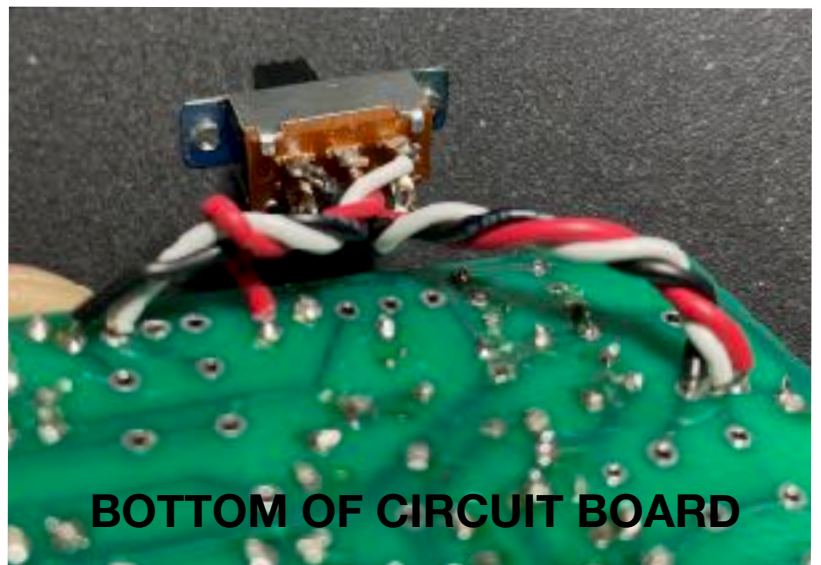
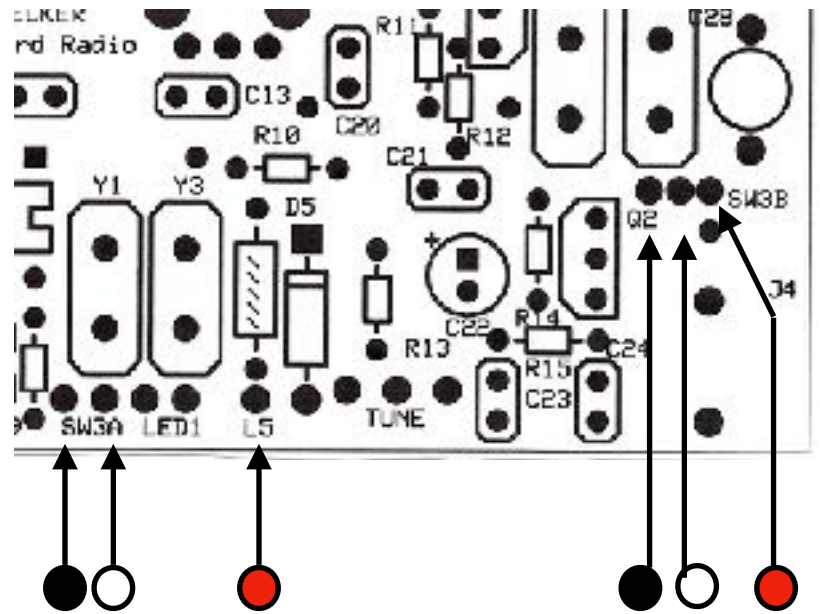
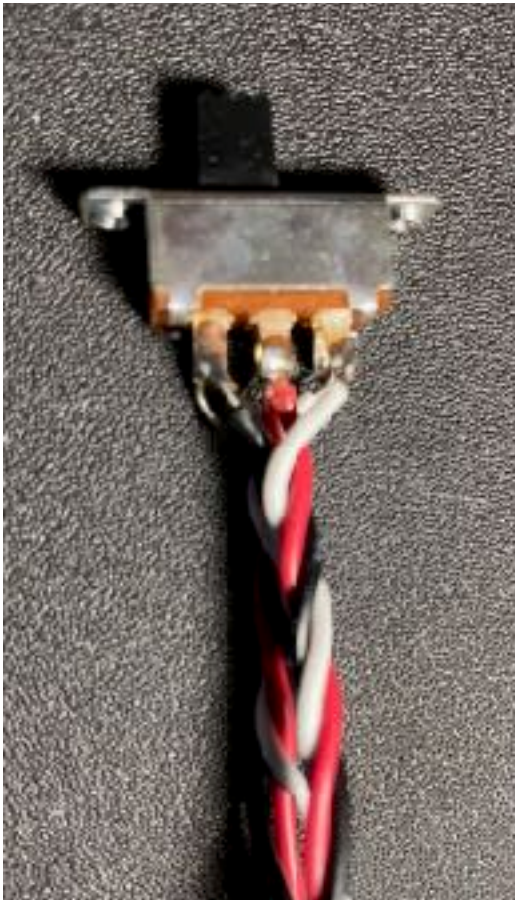

## Assembly of the Base, Front Panel and Top and Sides

Prepare the Frequency switch with six 2 inch (red, white and black) wires as shown. Strip 3/8 inch of insulation from each end. Make good mechanical connections before soldering. Then twist the wires together as shown. Make both rows identical (black, red, white). Be careful not to short top row to bottom row of wires. Pass stripped ends of wires through the bottom of the board and solder from the top of the board.

The Woodpecker circuit board is mounted on a thin (1/4th in.) Basswood plywood sheet. The front panel and side supports are 1/8th inch. Do not be concerned that the case is made from wood! It is strong, light weight and easy to assemble. Most radios of the first half of the 20th century were of similar construction. When finished, you have the option of painting or staining the cabinet as you like...be creative. Also this design allows you to show your work. We call this the "presentation" view. A top and sides may also be added if desired (contact us to order the additional parts).

All of the parts are pre-cut and will be attached by Gel Super Glue. This can be found at craft and home improvement stores. **DO NOT TRY** Liquid super glue!! The brand I use is LOCTITE Ultragel Control. This type of super glue is easy to apply and sets in a few minutes. Follow safety instructions with the glue. Use sparingly and only on one surface. You will need to hold the pieces in place for two or three minutes before the glue will set. Then set aside for five minutes to cure.

STEP 1. Attach the two triangular supports to the base (1/4 inch thick rectangle). Use a sheet of copier paper to work on. Lightly sand the edge to be attached. Apply glue to the edge to be glued. Align the the two surfaces as shown and firmly hold in place for two or three minutes. The pieces must join as close to 90 degrees as is possible. Once the glue is set, leave it still to cure for five minutes.

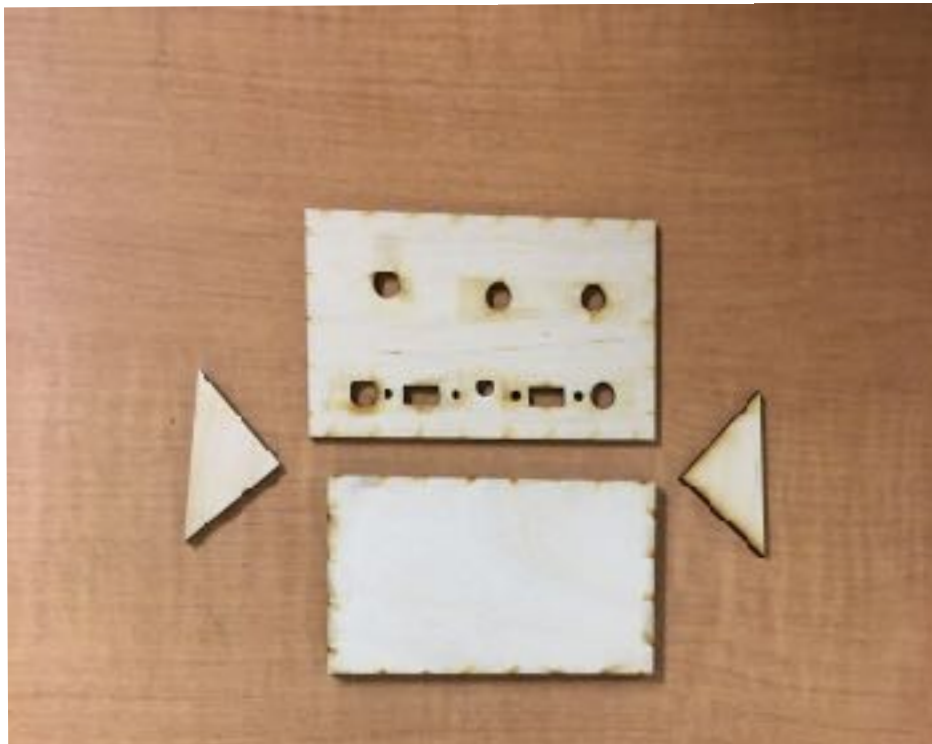

The joint may be glued to the sheet of paper. If so, gently peel the paper away. Any remaining paper should be sanded away with fine sand paper before painting.

Repeat this process for the other side support.

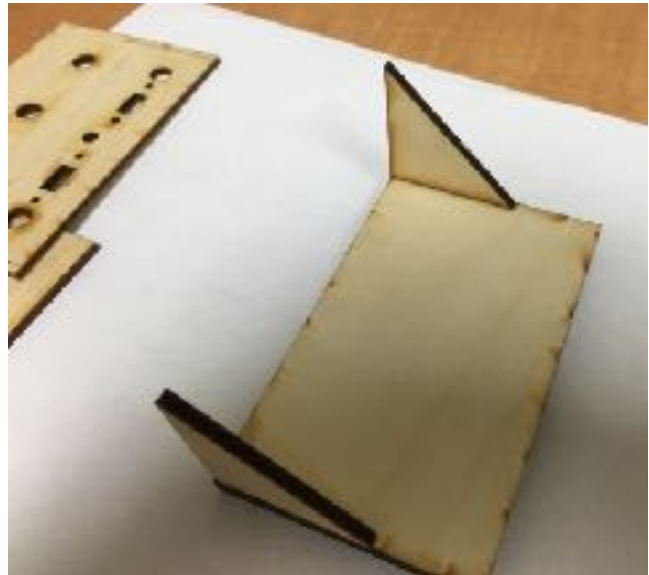

STEP 2. The base, now with the two triangular side supports, will be glued to the front panel. It needs to be centered so that the triangular supports and base leave 1/8th inch of space on each side.

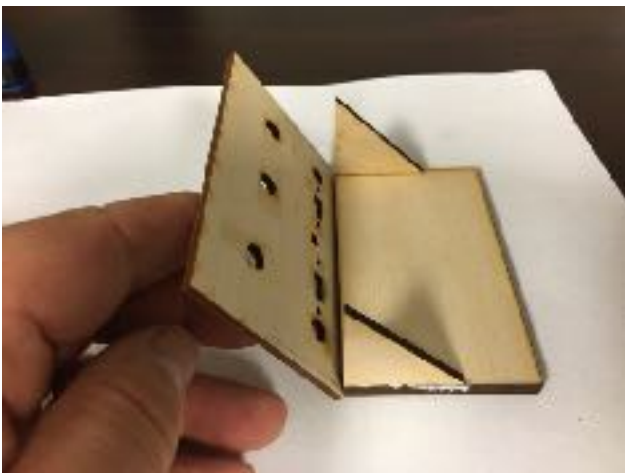

The front panel needs to overlap the base and triangular supports by 1/8th inch on each side.

Apply glue to the front edges of the base and triangular supports. With the base sitting flat, align the “centered” front panel and hold in place for about two minutes.

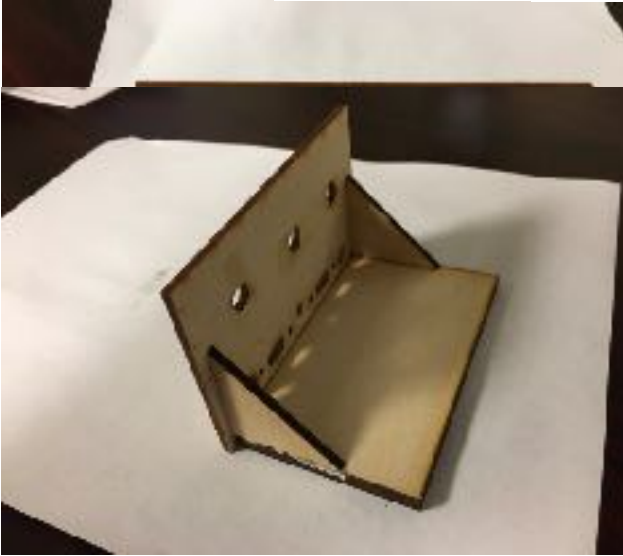

Once the glue has set, let the finished base and front panel cure for at least 15 minutes. The edges where paper is attached should be lightly sanded to remove the paper and prepare for painting. I like to use satin grey with a brush, but you may use any color you prefer brush or spray. If you paint the edges of the wood parts, I suggest sanding first to remove some of the dark color left by the laser cut.

### Painting The Cabinet



Painting the Woodpecker is where you get to add a personal touch to your project. Be creative and choose a color scheme of your own. My personal choice is grey for the inside and black, for the edges. You can use spray paint or brushed on colors. TIP: You can purchase small sample jars at home improvement stores for less than a can of spray paint and choose from hundreds of colors! It is also neater and cleans up with soap and water.

You can lightly sand all surfaces before you begin. Paint all surfaces of the base, front panel and support triangles. Give extra attention to the darker edges so as to cover well.

After painting and letting the paint dry, the front panel decal will be applied and trimmed.

### Mount Front Panel Decal (Note: photos show the 60 meter version decal)

The front panel decal is made of heavy clear coated vinyl plastic with die cut holes. The hole cutouts must first be carefully removed. A hobby knife works well for this purpose.

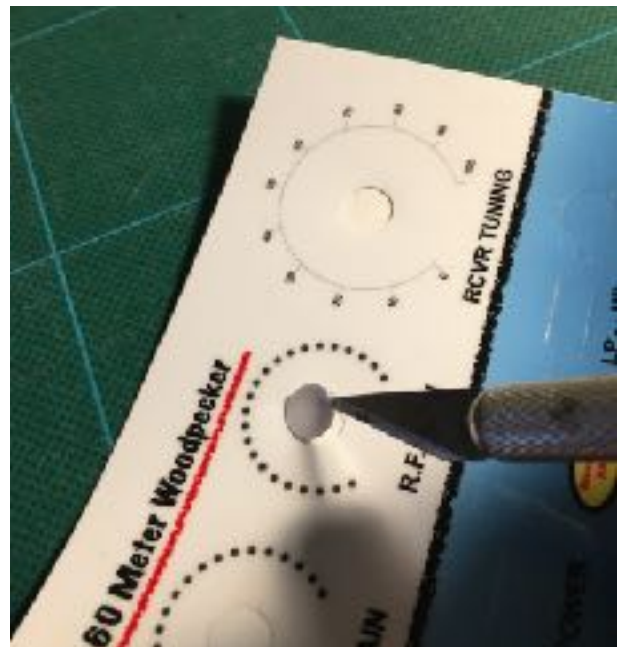

Once all the holes have been removed, the decal backing must be peeled off of the back of the decal. Carefully line up the holes with the cut out holes in the front panel wood.

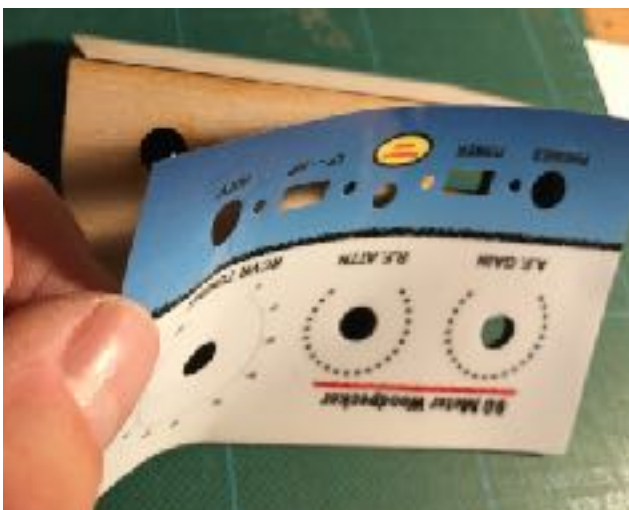

Note that the decal has overlap on all four sides. Lay the front panel face down on a clean firm surface like a cutting board or firm piece of cardboard. Use the hobby knife to trim off the overlapping sides of the decal. Use the edges of the front panel wood as a guide.

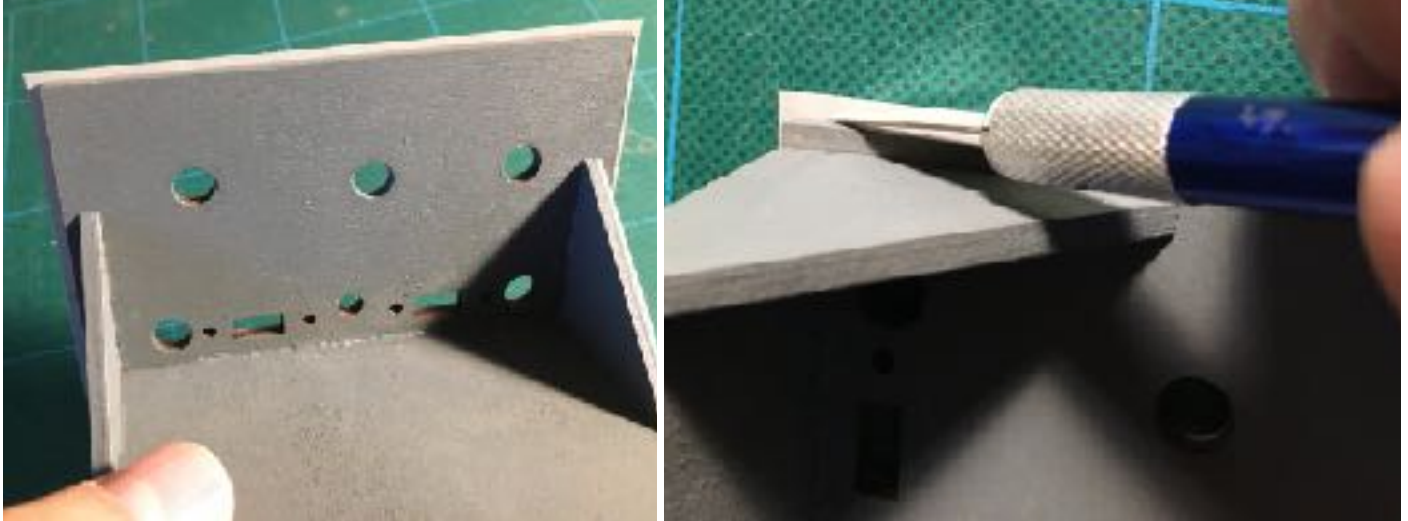

Sharp, clean cuts and careful line up of the holes will make a nice looking job!

## Mount circuit board and panel controls



Position the circuitboard on the bottom of the cabinet as shown. Slide forward while aligning the phone and key jacks, switches and LED to fit through the front panel holes. Using a small flat blade screwdriver below the circuit board may aid in aligning the switches and LED to fit in the holes.



**Note: Place a piece of electrical tape over the circuitboard side of the switches to prevent shorts with the circuitboard traces!**

Secure the switches with the supplied four #2 machine screws. DO NOT over tighten the screws as this will distort the decal. Next, remove (break off) the metal mounting tabs on the front of the potentiometers and mount through the appropriate holes as shown. Secure the Potentiometers with the supplied washers and nuts.





Push the LED mounting clip through the LED hole from the front of the panel. Use the screwdriver from behind to push the LED into the clip, but not all the way! The LED lens must be recessed part way.

Place the knobs on the potentiometer shafts.



From the top of the circuit board, drill a 1/16 inch mounting hole using the corner mounting holes in the circuit board as a guide. It will not matter if the drill bit goes all the way through the wood.

Using two 7/8 inch screws and four 1/4 inch black spacers, secure the circuit board.

Place the four peel-off and stick-on feet on the bottom of the cabinet.



## **Using the 40 meter Woodpecker**

### **Alignment**

Tune the receiver bandpass filter (T1) for the loudest signal. This can be an actual signal on your crystal frequency or a signal from a signal generator or nearby transmitter.

The transmitter only needs to have its output frequency set by trimmer capacitor C30. Note that only one crystal (Y2 or Y4) can be set. The other crystal will be near the stamped frequency.

### **Antenna**

QRPp success depends on a good antenna. During testing, good results were obtained with a resonate 40 meter dipole and an OCFD with tuner. Use of a good antenna tuner is recommended if the antenna has a high SWR. Note: A slightly distorted sidetone note is an indication of a high SWR. We used an Elecraft T1 portable tuner.

### **Operating Voltage**

Use 12.0 to 14.0 volts from a clean power supply with shielded supply cable or batteries.

### **Noise**

Static crashes, strong shorewave stations and other band noise are a fact at times. Use of the attenuator and high/low tone switch can help.

### **Receiver tuning**

The Tuning control allows you to receive about half a KHz above and below which allows you to choose a cw tone you like.

## **Transmitting**

The front panel key jack will allow your key or most electronic keyers to be used. When keyed, the transmitter sends a sidetone to the phone jack and mutes the receiver. This circuit has about a one second delay (which can be changed by changing one capacitor). This one second delay works well with operating speeds up to about 15-20 w.p.m. The delay also reduces the “thuds” heard as the mute cuts out.

## **Success on 40 meters**

Forty meters is a great QRPp band. If you are new to the band or to QRPp, please be aware that: Band conditions vary and signals may be weak or strong. You will have more luck with the strong signals. In my experience there are more stations to work in the evening, but I have also worked stations in the morning and early afternoon. Use slower code speeds. I often leave the woodpecker running in the background when I am working in my shack. That way I can hear when others are operating. Be patient, and persistent and you will have fun!

## **Problems**

If you have any problems with your kit, please email us at:  
[w4fsv@breadboardradio.com](mailto:w4fsv@breadboardradio.com) You can also refer to our website at:  
[www.breadboardradio.com](http://www.breadboardradio.com)